

Mechanical Design

CATIA - Part Design Feature Recognition 1 (FR1)

CATIA V5R18

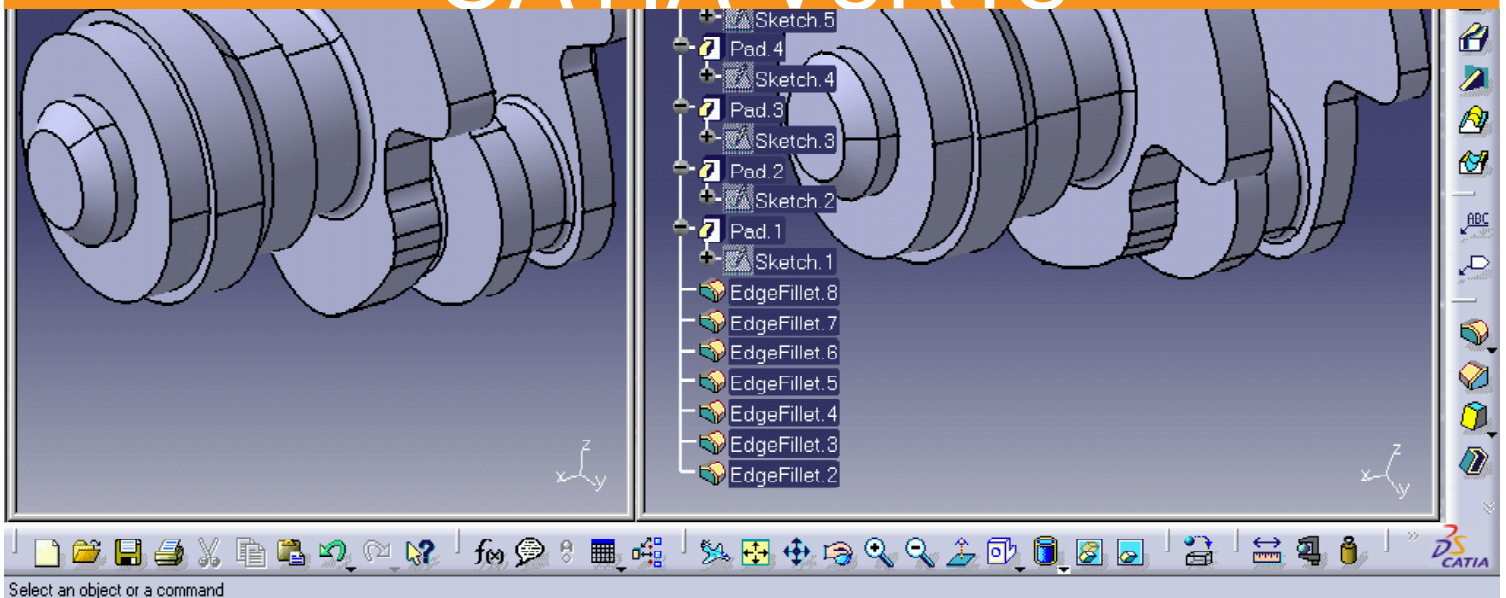

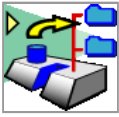

Mechanical Design

CATIA - Part Design Feature Recognition

Recognize Part Design features of an Isolated B-Rep

Product overview

CATIA - Part Design Feature Recognition 1 (FR1) is intended to recognize Part Design feature from an Isolated B-Rep. This product is used to retrieve a comprehensive CATIA data structure (Product Structure) from an Isolated B-Rep Part. The user imports a part and can recover elementary Part Design features.

CATIA - Part Design Feature Recognition 1 (FR1) is used to allow better downstream applications integration, to improve Part simplification for tool definition and flexible local design.

Product Highlights

- Offers advanced tools for Post-Modification on isolated solids coming from external systems or standard formats
- Recreates Part design features from a Global recognition tool that analyses the whole isolated solid
- Recreates Part design features based upon faces selection for a precise and efficient local recognition

Product Key Customers Benefits

Offers advanced tools for Post-Modification on isolated solids coming from external systems or standard

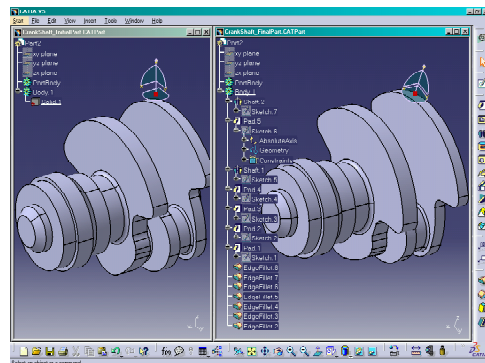

formats

Recreates Part design features from a Global recognition tool that analyses the whole isolated solid

Recreates Part design features based upon faces selection for a precise and efficient local recognition

ABOUT CATIA V5R18

CATIA is Dassault Systemes' PLM solution for digital product definition and simulation.

plm.3ds.com/CATIA

